



UNICUS
OLYMPIADS

#UnicusIsUnique

Sample Paper



Class 6

Unicus Global Science Olympiad (UGSO)

Time: 60 minutes

Pattern and Marking Scheme			
Section	Total Questions	Marks per Question	Total Marks
Classic Section	30	1	30
Scholar Section	15	2	30
Grand Total	45		60

Unicus Global Science Olympiad (UGSO)

The **Unicus Global Olympiad** is organised around two dimensions:

1. Content dimension, specifying the subject matter domains to be assessed
2. Cognitive dimension, specifying the thinking processes to be assessed

Target percentages of the question paper devoted to cognitive domains

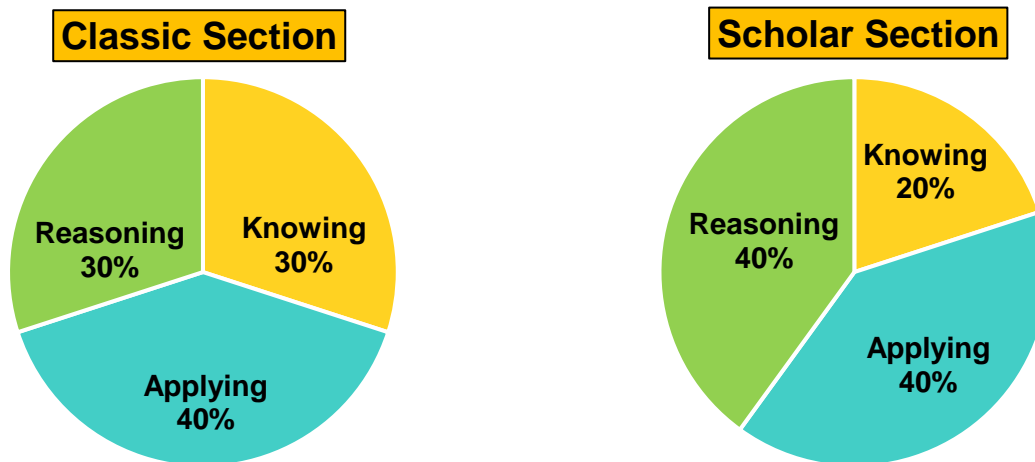

Target percentages of the question paper devoted to content domains

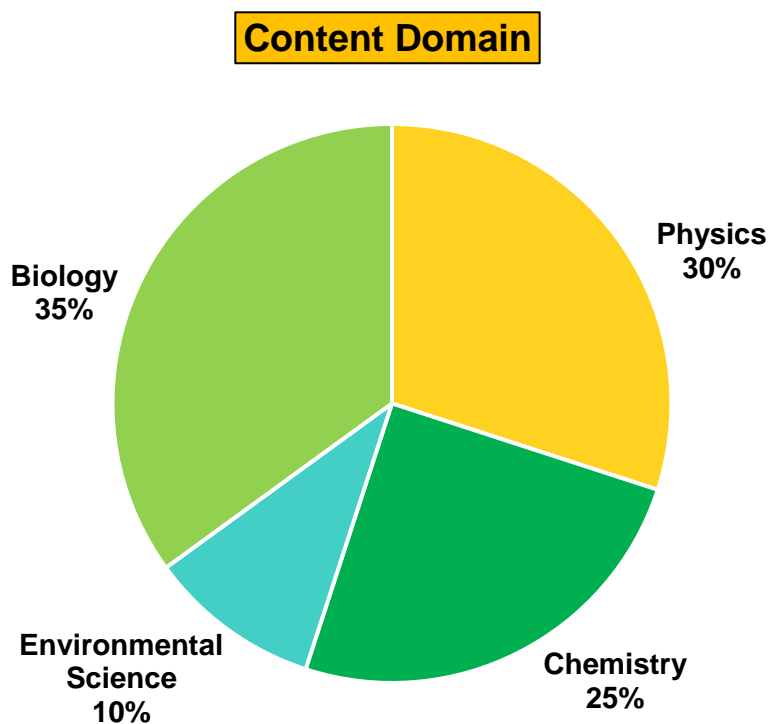

For more details, visit <https://www.unicusolympiads.com/>.

Classic Section (Each Question is 1 Mark)

Cognitive Domain: Knowing

Content Domain: Physics

1. If an object's velocity changes, what must be occurring?
- a. The object must be increasing its mass.
 - b. The object must be accelerating.
 - c. The object must be falling freely.
 - d. The object must be stationary.

Cognitive Domain: Applying

Content Domain: Physics

2. A skating rink is perfectly circular and it has a radius of 14 m. A skater circles the rink on the outer edges near the wall. When the skater is half way around the circle what is her distance and what is her displacement?
- a. 40 m, 14 m
 - b. 44 m, 0 m
 - c. 44 m, 28 m
 - d. 0 m, 28 m

Cognitive Domain: Reasoning

Content Domain: Physics

3. Look at the graph below. It shows how three runners ran a 100 m race.
- A. Which runner won the race?
 - B. How long did Bob take to complete the race?

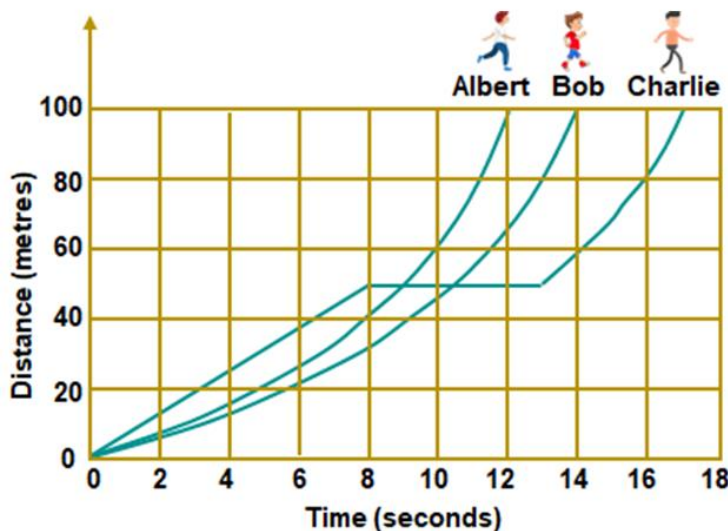

- a. A - Albert, B - 14 s
- b. A - Bob, B - 14
- c. A - Charlie, B - 17 s
- d. A - Albert, B - 12 s

Cognitive Domain: Reasoning

Content Domain: Physics

8. A person walks parallel to a series of N perfectly aligned plane mirrors spaced a constant distance (d) apart at a constant speed (v). The mirrors are infinitely wide and extend infinitely in both directions.
- What will the person observe as they walk past the mirrors?
- They will see multiple reflections of themselves, each appearing smaller and moving faster.
 - They will see multiple reflections of themselves, each appearing larger and moving slower.
 - They will see a single reflection of themselves, appearing to move at the same speed as they do.
 - They will see no reflections of themselves due to the infinite extension of the mirrors.

Cognitive Domain: Knowing

Content Domain: Physics

9. A light bulb is lit up in a closed circuit. If you were to replace the copper wire in the circuit with a saltwater solution, what would likely happen to the brightness of the bulb?
- The bulb would become brighter as saltwater conducts electricity very well.
 - The bulb would remain the same brightness.
 - The bulb would dim or turn off completely because saltwater conducts with some resistance.
 - It's impossible to predict without knowing the exact concentration of salt in the water.

Cognitive Domain: Applying

Content Domain: Physics

10. Why are some wires in your house wrapped in a thick rubber casing while others have a thin plastic coating?
- Thicker casings are more colourful and aesthetically pleasing.
 - Thicker rubber provides better insulation for wires carrying a higher voltage.
 - Thin plastic is cheaper to produce.
 - The colour of the casing indicates the function of the wire.

Cognitive Domain: Reasoning

Content Domain: Physics

11. There are one battery, three identical light bulbs, and a switch in the following circuit. Which of the following statements is/are correct?
- When the switch is closed, X and Y have the same brightness.
 - When the switch is closed, Y is dimmer than Z.
 - When the switch is open, X is dimmer than Z.

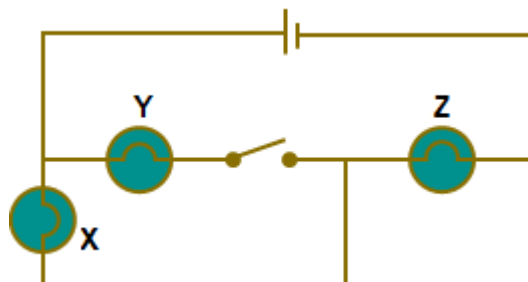

- a. A only
- b. B only
- c. A and B only
- d. B and C only

Cognitive Domain: Applying

Content Domain: Chemistry

12. Imagine you have a saltwater solution. You stir enough salt into the water at 40°C until no more will dissolve. What might happen if you cool the temperature of this saturated saltwater solution down to 20°C?
- a. The amount of salt dissolved in the water will likely stay the same.
 - b. The solution will remain saturated.
 - c. The solubility of salt will increase.
 - d. Salt will begin to precipitate out.

Cognitive Domain: Reasoning

Content Domain: Chemistry

13. Three identical balloons are filled with different gases: helium (He), air (a balloon filled with a mixture of gases, primarily nitrogen and oxygen), and carbon dioxide (CO₂). All balloons are inflated to the same size and placed at room temperature. After a few hours, you observe that the balloons have shrunk at different rates. You plot the data in the graph given below. What explains the observed difference in how much the balloons shrunk?
- A. Helium, being lighter and smaller, diffuses out faster.
 - B. All gas molecules eventually escape the balloon.
 - C. Balloons filled with CO₂ will float better than those with helium.

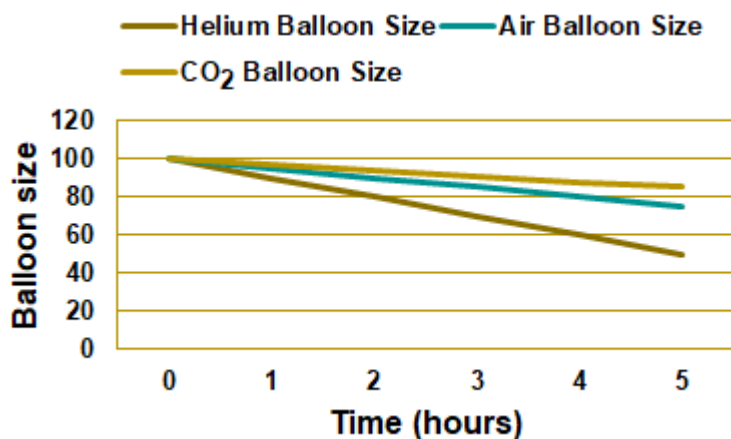

- a. A only
- b. A and B only
- c. B and C only
- d. A, B and C

Cognitive Domain: Knowing

Content Domain: Chemistry

14. During a day, the temperature rises in the morning, reaches a peak at noon, and falls again in the evening. This cycle repeats daily. How would you classify this change?
- a. An irreversible physical change
 - b. A reversible chemical change
 - c. A reversible periodic change
 - d. A reversible non-periodic change

Cognitive Domain: Applying

Content Domain: Chemistry

15. During a camping trip, you successfully light a bonfire using firewood. As the fire crackles and burns brightly, you feel a wave of warmth radiating outwards. Why does the bonfire feel warm?

- A. The breaking of bonds in the wood releases energy.
- B. The reaction between wood and oxygen is endothermic.
- C. The burning wood absorbs the cold from surroundings.

- a. A only
- b. A and B only
- c. B and C only
- d. A, B and C

Cognitive Domain: Applying

Content Domain: Chemistry

16. Liam has a metal strip that appears shiny and silver. He performs two experiments:

Experiment 1: He leaves the metal strip exposed to moist air for a few days. The strip develops a brown rusty coating.

Experiment 2: He heats the metal strip with a blowtorch. The metal melts and turns into a liquid.

Based on these observations, which of the following statements is CORRECT?

- a. The metal has undergone a chemical change in both experiments.
- b. The metal has undergone a physical change in both experiments.
- c. Melting the metal is irreversible, but rusting is not.
- d. The brown coating is a new substance formed by a chemical change.

Cognitive Domain: Reasoning

Content Domain: Chemistry

17. You are given a setup shown in the diagram with a beaker of water and a thermometer. The temperature of the water is changing over time as heat is continuously applied.

Which of the following statements accurately describes the change in water based on the graph?

- A. The water molecules are breaking apart and forming a new substance.
- B. The water particles are rearranging themselves, but their chemical composition remains the same.
- C. The water has reached its boiling point and will now transform into steam (a gas).

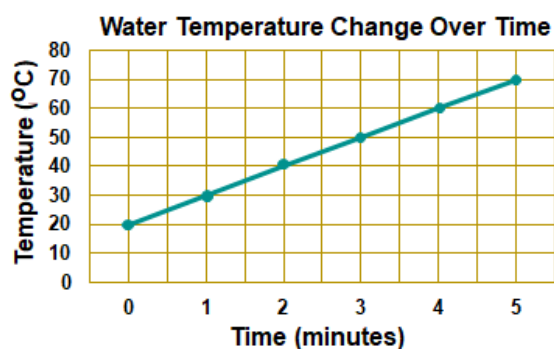

Unicus Global Science Olympiad (UGSO)

- a. A and C only
- b. B and C only
- c. B only
- d. C only

Cognitive Domain: Knowing

Content Domain: Biology

18. Many fruits have vibrant colours. Which cell organelle is most likely responsible for these colours?

- a. Cell wall
- b. Vacuole
- c. Plastids
- d. Nucleus

Cognitive Domain: Applying

Content Domain: Biology

19. Violet drew a picture of a cell. Identify what is wrong with it.

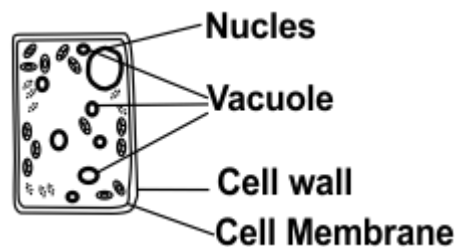

- a. The drawing shows a cell membrane, which is absent in plant cells.
- b. The drawing shows only one nucleus.
- c. The inner layer should be labelled as cell wall and outer layer should be cell membrane.
- d. The drawing shows multiple small vacuoles instead of a single large one.

Cognitive Domain: Applying

Content Domain: Biology

20. An animal cell does not have a cell wall, but a plant cell does. Why do you think this difference exists?

- A. Animal cells are smaller and don't need the support.
 - B. Plant cells need more support because they are larger and don't move.
 - C. Animal cells can move and a cell wall would hinder that.
- a. A only
 - b. A and B only
 - c. B and C only
 - d. A, B and C

Cognitive Domain: Knowing

Content Domain: Biology

21. The human respiratory system includes several key components. Which of the following is NOT a part of the human respiratory system?

- a. Trachea
- b. Alveoli
- c. Ureter
- d. Bronchi

Cognitive Domain: Applying

Content Domain: Biology

22. Sam eats a large meal that includes proteins, fats, and carbohydrates. Estimate the order in which these nutrients will begin to be digested in Sam's digestive tract.

- a. Proteins, fats, carbohydrates
- b. Carbohydrates, proteins, fats
- c. Fats, proteins, carbohydrates
- d. Proteins, carbohydrates, fats

Cognitive Domain: Applying

Content Domain: Biology

23. Our bones provide structure and support for our bodies. Interestingly, many bones are not completely solid but have a hollow interior.

What is the advantage of having hollow bones?

- A. They make the skeleton lighter while maintaining significant strength.
- B. They can store more calcium for strength.
- C. They are more flexible.

- a. A only
- b. A and B only
- c. A and C only
- d. A, B and C

Cognitive Domain: Knowing

Content Domain: Biology

24. Mushrooms, moss, and bread moulds are all eukaryotic organisms with unique characteristics. Which of the following statements is true about all three groups?

- a. All are beneficial organisms that can be used in food production.
- b. All reproduce primarily through spores.
- c. All can be found growing on living plants or animals as parasites.
- d. They are all important food sources for herbivores.

Cognitive Domain: Reasoning

Content Domain: Biology

25. The table below shows some key adaptations of four animals: L, M, N, and O. Based on the information in the table, which of the options correctly matches each animal to its most likely habitat?

	Habitat	Animal
A.	Arctic	L, N, O
B.	Arctic	L
C.	Rainforest	M, O
D.	Rainforest	M, N, O

- a. A
- b. B
- c. C
- d. D

Cognitive Domain: Knowing

Content Domain: Environmental Science

29. Ecosystems can be classified based on various factors such as climate, vegetation, and geographical location.

How does the classification of ecosystems help scientists and conservationists?

- It allows scientists to predict weather patterns in different regions.
- It has no practical significance in environmental science.
- It enables them to manipulate ecosystems for human convenience.
- It provides insight into the distribution of species and their habitats.

Cognitive Domain: Reasoning

Content Domain: Environmental Science

30. The diagram below shows a simplified food web with three groups of organisms (A, B, and C) and the cycling of oxygen. The dotted arrows show how oxygen moves between the environment and the organisms.

Based on the food web, which of the following correctly identifies the three groups of organisms?

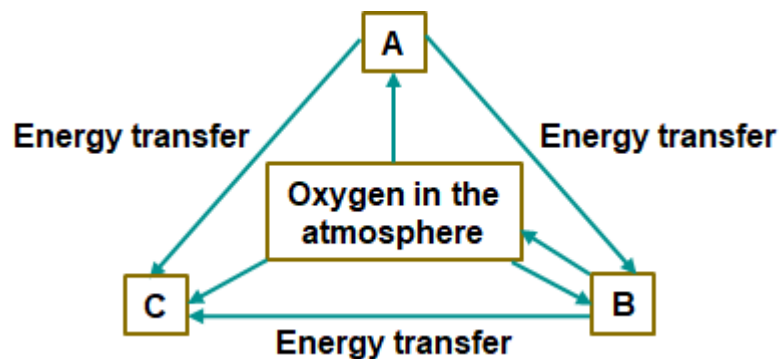

- A: Consumers, B: Producers, C: Decomposers
- A: Producers, B: Consumers, C: Decomposers
- A: Decomposers, B: Producers, C: Consumers
- A: Consumers, B: Decomposers, C: Producers

Scholar Section (Each Question is 2 Marks)

Cognitive Domain: Applying

Content Domain: Physics

31. The given graph illustrates a cyclist's trip with a gradual increase in distance, a steady period, and a sharp increase.

During which period was the cyclist likely ascending a steep hill?

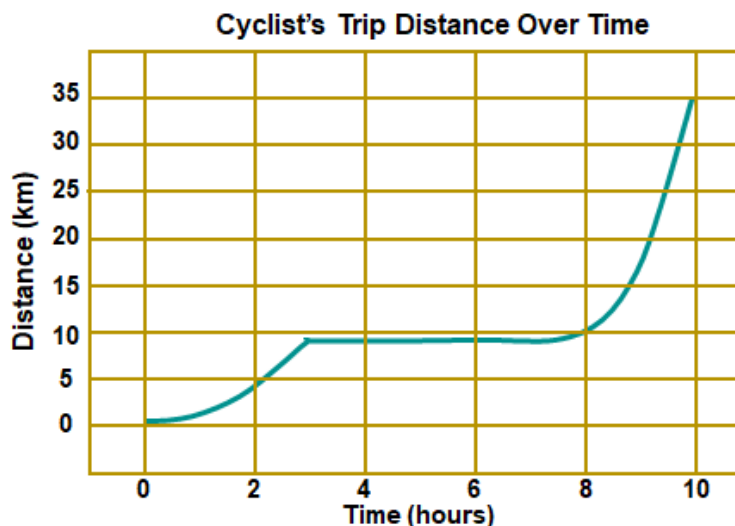

- a. During the gradual increase
- b. During the steady period
- c. During the sharp increase
- d. After the sharp increase

Cognitive Domain: Reasoning

Content Domain: Physics

32. Peter set up the circuit shown below to find out if materials W, X, Y and Z are electrical conductors or insulators.

She recorded her results in the table below.

Which of the following correctly identifies the electrical conductor(s) and insulator(s)?

Bulb	Did the bulb light up?
B1	No
B2	Yes
B3	Yes

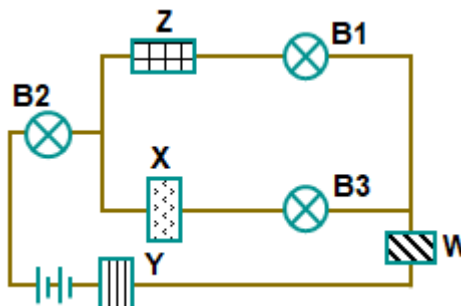

- a. Electric insulators: W, X and Y, Electric conductor: Z
- b. Electric insulators: X and Y, Electric conductors: W and Z
- c. Electric insulators: Y and Z, Electric conductors: W and X
- d. Electric insulator: Z, Electric conductor: W, X and Y

Cognitive Domain: Reasoning	Content Domain: Chemistry
------------------------------------	----------------------------------

33. A student has a beaker filled with a mixture of hot sand and water, both at 60°C. They place a metal plate chilled in the refrigerator (at 20°C) into the beaker as shown in the setup below. Select the option that shows the thermal energy (heat) transfer between the substances:

	Energy flows from	Energy flows to	According to setup
A.	Areas of high particle vibration	Areas of lower vibration	Sand/water - Metal plate
B.	Areas of lower vibration	Areas of high particle vibration	Metal plate - Sand/water
C.	Areas of high particle vibration	Areas of lower vibration	Metal plate - Sand/water
D.	Areas of lower vibration	Areas of high particle vibration	Sand/water - Metal plate

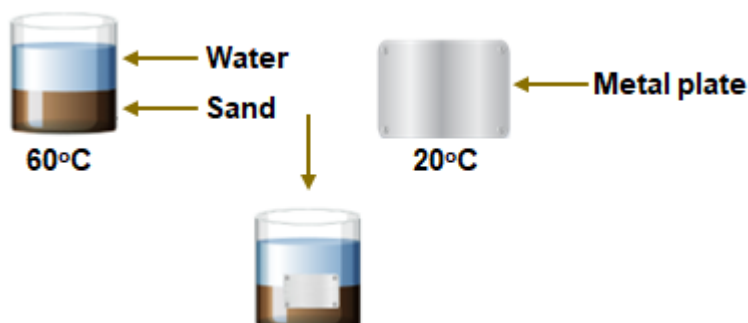

- | | |
|------|------|
| a. A | b. B |
| c. C | d. D |

Cognitive Domain: Reasoning	Content Domain: Biology
------------------------------------	--------------------------------

34. Some students are studying three different cell types, labelled A, B, and C. They created a table to summarise the presence (Yes) or absence (No) of certain cell parts. Based on the information in the table, which of the following statements about the cells is most likely true?

	Cell A	Cell B	Cell C
Cytoplasm	Yes	Yes	Yes
Cell wall	No	Yes	Yes
Chloroplast	Yes	No	No
Cell Membrane	Yes	No	Yes

- a. All three cells (A, B, and C) can reproduce.
- b. Cell A is a plant cell because it has a chloroplast.
- c. Cell B can move around its environment because it has a cell wall.
- d. All three cells (A, B, and C) can transport materials into and out of the cell.

Cognitive Domain: Reasoning	Content Domain: Biology
------------------------------------	--------------------------------

35. A chart below illustrates how food particles and another substance, labelled "R," are transported within the human body. Based on the information provided, what are the MOST LIKELY identities of the two transport systems (X and Y) and substance R?

	System X	System Y	Substance R
A.	Digestive system	Respiratory system	Oxygen
B.	Digestive system	Respiratory system	Blood
C.	Digestive system	Nervous system	Oxygen
D.	Respiratory system	Digestive system	Carbon dioxide

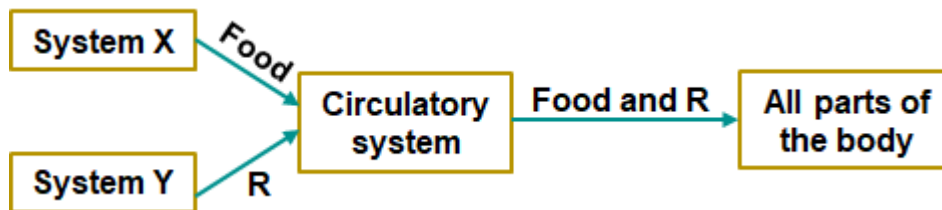

- | | |
|------|------|
| a. A | b. B |
| c. C | d. D |

Cognitive Domain: Applying	Content Domain: Biology
-----------------------------------	--------------------------------

36. Sea lions, otters, and walruses are all agile swimmers despite being land mammals. Which of the following adaptation(s) is/are found in these animals, allowing them to move efficiently in the water?

- A. Streamlined bodies for reducing water resistance
- B. Webbed feet or flippers for propelling forward
- C. Ability to breathe underwater for hours

- | | |
|-----------------|-----------------|
| a. A only | b. A and B only |
| c. B and C only | d. A, B and C |

Cognitive Domain: Applying	Content Domain: Biology
-----------------------------------	--------------------------------

37. Germs and viruses can spread in a classroom environment through various means, posing a health risk to students and teachers.

- A. A student with a cold shares a water bottle with a friend.
- B. A student touches a contaminated doorknob and then rubs their eyes.
- C. A student coughs directly onto another student's face.



Unicus Global Science Olympiad (UGSO)

- a. A only
- b. A and B only
- c. B and C only
- d. A, B and C

Cognitive Domain: Knowing

Content Domain: Environmental Science

38. The diagram below shows the water cycle. Arrows represent the movement of water between different stages.
If deforestation increases significantly, which of the following changes would be observed in the water cycle?

- A. More frequent and heavier rainfall.
- B. Decreased transpiration from plants.
- C. Reduced water infiltration into the ground.

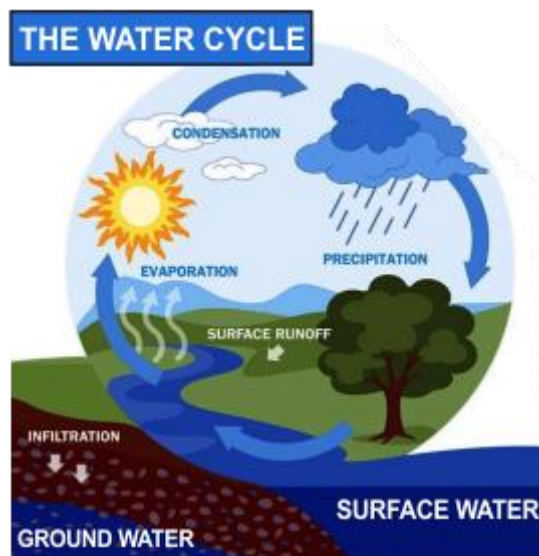

- a. A only
- b. B only
- c. B and C only
- d. A, B and C

Cognitive Domain: Applying

Content Domain: Environmental Science

39. The graph below shows the population of organism X in a park over several weeks. Also, organism Y was seen in the park starting from week five.
What is the likely explanation for the observed changes in the population of organism X?

- A. Organism Y is a predator of organism X.
- B. Organism Y competes with organism X for food resources.
- C. Organism Y is the prey of organism X

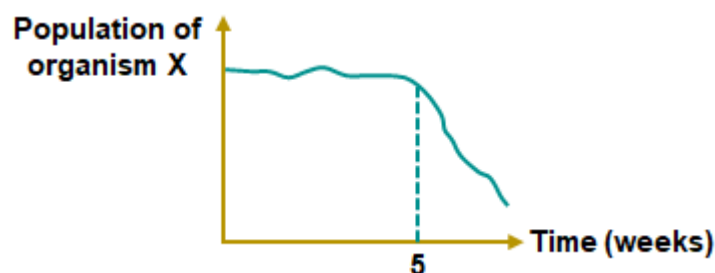

Unicus Global Science Olympiad (UGSO)

- a. A only
- b. A and B only
- c. B and C only
- d. A, B and C

Direction (for questions 40 to 42): Read the passage carefully and answer the questions accordingly:

Magnetic interactions play a crucial role in our everyday lives, from the compasses that guide explorers to the magnetic locks securing doors. At its core, magnetism is the force exerted by magnets when they attract or repel each other. A magnet has two poles: north (N) and south (S). Opposite poles attract, while like poles repel.

One of the simplest experiments to understand magnetic interaction involves using a set of small bar magnets and iron filings. When a bar magnet is placed under a sheet of paper sprinkled with iron filings, the filings align along the invisible lines of magnetic force emanating from the magnet. These lines, known as magnetic field lines, flow from the north pole to the south pole outside the magnet, as illustrated in the table below.

Understanding how magnets interact helps in developing more efficient technologies in fields such as transportation, where magnetic levitation (maglev) trains glide over tracks, dramatically reducing friction.

Position on Paper	Iron Fillings Pattern
Near North Pole	Radiating outward
Center of Magnet	Dense and straight
Near South Pole	Radiating outward

Cognitive Domain: Applying

Content Domain: Physics

40. Why would a magnetic levitation (maglev) train ride be smoother than a traditional train ride?
- a. Because maglev trains are newer
 - b. Because magnetic force eliminates direct contact with the tracks, reducing friction
 - c. Because maglev trains are faster
 - d. Because magnetic trains use less electricity

Cognitive Domain: Knowing

Content Domain: Physics

41. Why do the iron filings show a pattern of radiating outward near the poles of the magnet?
- a. Because the magnetic field is weakest at the poles
 - b. Because the magnetic field is strongest at the poles
 - c. Because the magnetic field lines are spreading out from the pole
 - d. Because the iron filings are more attracted to the paper than to the magnet

42. How does the orientation of a bar magnet under a sheet of paper affect the pattern formed by iron filings?
- The pattern does not change with the magnet's orientation.
 - Horizontal placement results in circular patterns, while vertical placement leads to straight lines.
 - The filings form denser patterns when the magnet is vertical than when it is horizontal.
 - The filings align perpendicularly to the magnet regardless of its orientation.

Direction (for questions 43 to 45): Consider the passage given below and answer the following question:

Exploring Mixtures: A Dive into Diversity

In the realm of chemistry, mixtures play a vital role in both natural environments and human-made products. A mixture is a combination of two or more substances where each substance retains its chemical identity and properties. Mixtures can be categorised into homogeneous and heterogeneous groups based on the uniformity of their composition.

Homogeneous Mixtures: These are mixtures that have the same composition throughout. They are also known as solutions. A classic example is salt water, where salt (sodium chloride) is uniformly distributed throughout the water. On a microscopic level, the particles of salt are so well mixed that they cannot be seen separately from the water.

Heterogeneous Mixtures: Unlike homogeneous mixtures, these do not have a uniform composition throughout. Various parts of the mixture show different properties. An example is a salad, where each ingredient like lettuce, tomatoes, and cucumbers can be seen and picked out individually.

To illustrate these concepts, consider the table below which lists common household mixtures and their types.

Understanding these types enables us to analyse how mixtures are formed and how they can be separated. For example, a salad (heterogeneous) can be easily separated by hand, whereas separating salt from salt water (homogeneous) requires evaporation, a process where water is converted to vapour, leaving salt behind.

Mixture	Type of Mixture	Components
Air	Homogeneous	Nitrogen, Oxygen, Carbon dioxide, etc.
Soil	Heterogeneous	Water, Air, Mineral Particles, Organic Matter
Vinegar	Homogeneous	Acetic Acid, Water
Concrete	Heterogeneous	Cement, Sand, Gravel, Water

Cognitive Domain: Knowing

Content Domain: Chemistry

43. The table lists air as a homogeneous mixture. Imagine a foggy morning. Does this contradict the information in the passage?
- The passage only refers to dry air, not air with moisture content.
 - Fog is a solution, and all solutions are homogeneous by definition.
 - No, the air is always homogeneous regardless of the presence of moisture.
 - Yes, fog is a heterogeneous mixture of water droplets and air.

Cognitive Domain: Reasoning

Content Domain: Chemistry

44. Consider a scenario where a closed container initially filled with a homogeneous mixture of air is heated. Based on the knowledge of mixtures, what can you predict about the composition of the air particles within the container after heating?
- The ratio of different gases in the air will change.
 - New types of gas molecules will be formed.
 - The individual gas molecules will become heavier.
 - The composition of air will remain the same throughout.
- A and C only
 - B only
 - C and D only
 - D only

Cognitive Domain: Applying

Content Domain: Chemistry

45. Analyse the table provided in the passage. Which of the following correctly describes the relationship between the type of mixture and the ease of separating its components?
- Homogeneous mixtures are always easier to separate than heterogeneous mixtures.
 - Heterogeneous mixtures are always easier to separate than homogeneous mixtures.
 - The ease of separation depends on the specific components of the mixture, not its type.
 - There is no relationship between the type of mixture and the ease of separation.

Answer Key

1.	b	2.	c	3.	a	4.	c	5.	a	6.	b	7.	a
8.	a	9.	c	10.	b	11.	a	12.	d	13.	b	14.	d
15.	a	16.	d	17.	c	18.	c	19.	d	20.	c	21.	c
22.	b	23.	a	24.	b	25.	c	26.	a	27.	b	28.	a
29.	d	30.	a	31.	c	32.	d	33.	a	34.	d	35.	a
36.	b	37.	b	38.	c	39.	b	40.	b	41.	c	42.	d
43.	d	44.	a	45.	c								